



MODEL 201
OPERATION AND MAINTENANCE MANUAL



Safety Summary



WARNING

In case of power cord damage, do not attempt to repair or replace the power cord. Contact the manufacturer or the local distributor.



WARNING

Hot Surface. Avoid contact.



CAUTION

During normal operation, the base of the machine needs to be installed or placed above the wall socket.



CAUTION

The machine is to be operated by one person only.



CAUTION

To reduce the risk of electric shock and injury to persons, disconnect from power supply before servicing and /or cleaning.

International Symbols



Power Off



Power On



Hot Surface



Risk of Electrical Shock



Protective Earth Terminal



Ground



Wet Conditions



Start Action



Caution - Warning



Disengage

Congratulations!

Your selection of the Insta Graphic Systems heat seal machine is a sound business decision. Insta equipment is the result of the highest quality engineering and time-tested design. Your new machine combined with Insta's reputation of innovation in the heat-sealing field, insures the continuing capability of delivering the best decorated substrates possible.

This manual describes installation, operation, and maintenance procedures for your new 201 machine, as well as easy to use instructions for on-the-spot maintenance.

Your 201 machine will have a long trouble-free life. Read this manual. Keep it with your machine; it's your key to proper operation and lasting service.

General Description

The Model 201 has been strategically designed to generate and evenly distribute tremendous pressure throughout the entire platen. And, its cast-in tubular heating element heats the metal from within, which produces constant and long lasting heat. A successful heat transfer application requires 3 key elements to work in tandem-time, temperature and pressure. The Model 201 has mastered those elements and gets the job done every time.

The manual swing-away machine has proven to be a true customer favorite. The upper platen swings to the right – leaving the lower platen completely free from constraints.

Limited Machine Warranty

Insta Graphic Systems warrants this heat seal machine, when operated under normal conditions, to be free from manufacturing defects in material and workmanship for a period of one year on parts (7 year on the heating element) and 90 days on labor from the invoice date.

This warranty will be effective only when Insta authorizes the original purchaser to return the product to the factory, freight prepaid, and only when the product upon examination has proven to be defective.

This warranty does not apply to any machine that has been subjected to misuse, negligence or accident.

Insta shall not be liable for the injury, loss or damage, direct or consequential, arising out of the use or the inability to use the product.

No claim of any kind shall be greater in amount than the sale price of the product or part to which claim is made.

This is the sole warranty given by the company, it is in lieu of any other warranties, expressed or implied, in law or in fact, including the warranties of merchant-ability and fitness for a particular use, and is accepted as such by the purchaser in taking delivery of this product.

FOR USE BY QUALIFIED PERSONNEL ONLY

Installation



201, S MODEL, 120 V
Use a **separate** 15 amp AC circuit. Only industrial extension cords with proper wire size should be used: size 16/3 wire for distances up to 25 feet, and size 14/3 for distances up to 50 feet.



201, T, D, G MODEL, 230 V
Use a **designated** 10-amp AC circuit. Only industrial extension cords with proper wire size (2.5 sq. mm) shall be used.



IMPORTANT
The appliance must be plugged into a proper receptacle of the proper size and rating. Equally important the line voltage must be able to accommodate this appliance as well as *other appliances operating on this circuit.*

Specifications

Voltage Model 201 (S)	120 Volts AC	50/60 Hertz
	1200 Watts	10.0 Amps
Voltage Model 201 (D,T,G)	230 Volts AC	50/60 Hertz
	1800 Watts	7.8 Amps
Machine Weight	Pounds (KG) 73.5 lbs. (33.3 Kg)	

Degree of Protection

IP (Ingress Protection) rating according to IEC 60529.

NOTE

IEC 60529 does not specify sealing effectiveness against the following: mechanical damage of the equipment; the risk of explosion; certain types of liquid conditions, e.g. those that are produced by condensation; corrosive vapor; fungus; vermin.

IP54 = IP
1st Digit 5
2nd Digit 4

1 st Digit	Protection from solid objects	2 nd Digit	Protection from moisture
0	Non protected	0	Non protected
1	Objects greater than 50mm	1	Dripping water
2	Objects greater than 12mm	2	Dripping water when tilted up to 15 deg.
3	Objects greater than 2.5mm	3	Spraying water
4	Objects greater than 1mm	4	Splashing water
5	Dust protected	5	Water jets
6	Dust tight	6	Heavy seas
--	---	7	.15m – 1m immersion
--	---	8	1m + submersion

Operation

1. Turn the machine on or off by pressing the **POWER** button on the controller.
2. Set the desired temperature and time.
3. Allow the machine to warm up until the selected temperature is reached.
4. Set the desired pressure by adjusting the pressure wheel on the top of the post.
5. Swing the upper platen arm to its fully open position, away from lower platen.
6. Place the substrate on lower platen, smoothing out all wrinkles.
7. Position transfer or lettering on substrate.
8. Swing the upper platen arm into position directly over the lower platen.
9. Close machine by pulling handle down into locked position.
10. The timer will start automatically and a buzzer will beep at the end of the time cycle.
11. Pull handle up slowly and move upper platen to its full open position. This technique will avoid transfer paper (cover) from being pulled off prematurely due to suction from the separating platens.



NOTE

For safety purposes, it is necessary to rotate the Upper Platen all the way to the back after it is lifted, until the stop position is reached. This will eliminate the accidental lowering of the heat platen handle.

12. Swing away the arm to the extreme right hand position and remove substrate.

Operational Timer/ Temperature Control

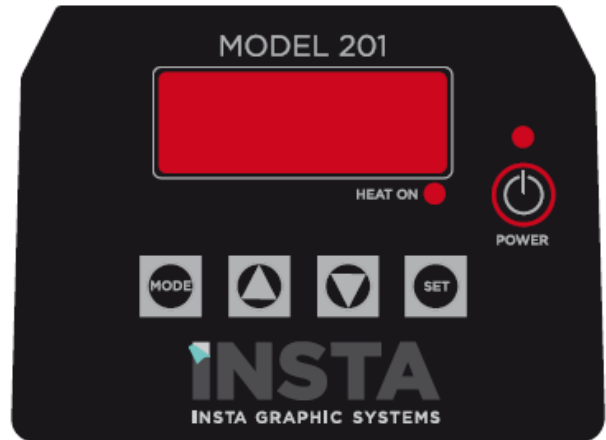

This controller has two (2) control features:

1. Temperature - Temperature may be set from 225 - 425°F (107-218°C).
2. Time - Time may be set from 1 second to 99 minutes and 59 seconds.



NOTE:

Operating the machine above 410°F (210°C) is not recommended. Using the machine at or above this temperature may lead to erratic controller behavior or gradual degradation of the high temperature limiter.

Controller Operation

Temperature Control

1. To display the temperature, push the **MODE** button until temperature is displayed.
2. While holding down **SET** button, push UP (↑) or DOWN (↓) arrow buttons to the desired temperature setting.

NOTE:

The temperature controller can be programmed to display the temperature in Fahrenheit or Celsius. To switch temperature scale, press the **MODE** button until the temperature is displayed, then push and hold both the **UP** (↑) and **DOWN** (↓) buttons for 5 seconds.

Timer Control

1. To display the timer, push the **MODE** button until time is displayed.
2. While holding down **SET** button, push UP (↑) or DOWN (↓) arrow buttons to the desired timer setting.

NOTE:

The controller has a count-down timer that automatically activates a buzzer at the completion of application.

The timer is displayed in minutes: seconds. The range is 00:00 to 99:59. While the timer is running, the colon (:) flashes.

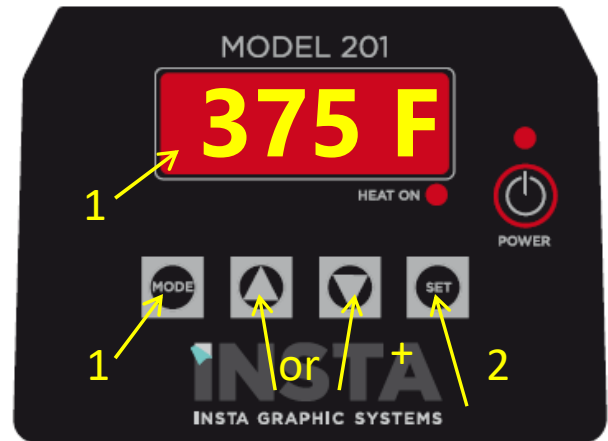

Steps for changing the set temperature.

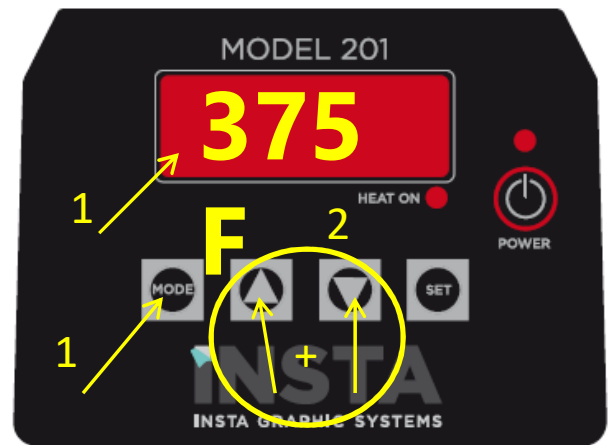

Steps for switching the temperature units.

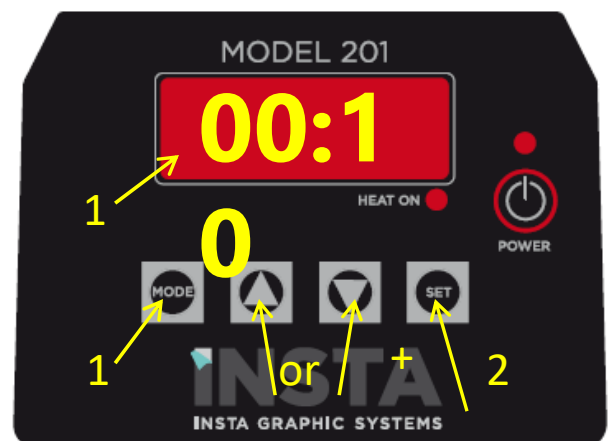

Steps for changing the timer length.

Automatic Shut Off

Model 201

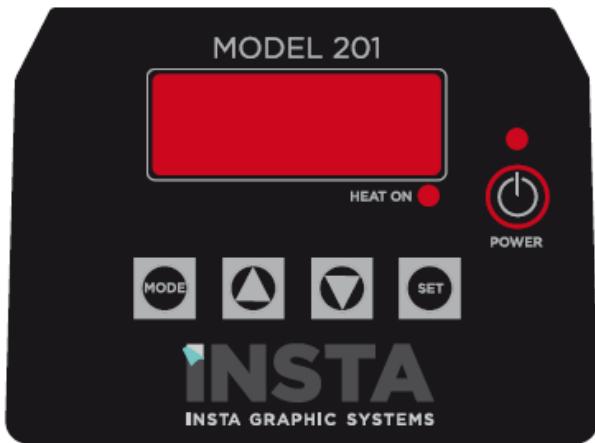

The Automatic Shut Off is designed to save electrical consumption and a safety feature when the user is not engaged in the usage of the Insta heat seal machines.

The factory setting for Automatic Shut Off is **2 hours**. The timer for Automatic Shut Off will begin after every key press or heat press cycle.

Any disturbances such as the key press, or heat press cycle will reset the timer.



NOTE

The Automatic Shut Off factory setting is ON.

Automatic Shut Off

1. Turn on the machine by pressing **POWER**.



- a) ONE beep indicates the Automatic Shut Off is **OFF**.
 - b) TWO beeps indicates the Automatic Shut Off is **ON**.
2. Press on the **MODE** once in order to display the **TIME SETTING**.
 3. With the TIME SETTING displayed, press and hold the **UP + DOWN ARROWS** for **3 to 5 seconds**.

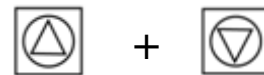

- a) ONE beep indicates the Automatic Shut Off is **OFF**.
 - b) TWO beeps indicates the Automatic Shut Off is **ON**.
4. Repeat step 3 in order to turn ON or OFF the Automatic Shut Off.

Preventive Maintenance Suggestions

Insta heat seal machines are relatively maintenance free. For long, trouble-free life, the following preventive maintenance should be followed:

1. Do not heat seal items such as buttons, pins, snaps, or zippers that tend to cut the silicone rubber pad or scratch the Teflon heat platen.
2. Clean the Teflon-coated heat platen periodically with a non-abrasive piece of cloth. Stubborn stains may be cleaned with mineral spirits **when the platen is cool**.
3. When the heat platen is hot and not in use, keep in open position (away from the silicone rubber pad).
4. To prevent soiling of substrate, periodic wiping of the entire exterior machine, including platens, with a clean rag is recommended. If necessary, use mineral spirits for cleaning a **cold** machine. Since mineral spirits are flammable, use precautions and keep away from sparks, flame, or hot heat platen.
5. The machine requires periodic lubrication with a high-temperature, non-melting grease (MPPL023).
 - Lubricate the Post, Guide Post, and Toggle assembly (Once every month if used continuously.)
 - There are three (3) points of lubrication:
 - Post
 - Toggle mechanism
 - Guide Post

In addition, occasionally apply a few drops of heavy machine oil to the upper portion of the toggle assembly.

General Maintenance

It is recommended that you have the following items available:

- A.Flat head screw driver
- B.Phillips head screw driver
- C.Small adjustable wrench
- D.Needle nose pliers with insulated handle
- E.Set of Metric Allen wrenches
- F.Grease gun
- G.Special high temperature grease MPPL023

With the above items you should be able to accomplish most repairs.



WARNING

Power cord replacement should be from the manufacturer only.

Replacement of Silicone Rubber Pads

1. Make sure the heat platen is cool.
2. Use tube of MPPC006 adhesive to bond silicone rubber pad to lower platen.
NOTE: *Read instructions on the adhesive package.*
3. Be sure that the surface of the silicone platen is clean. Use a **mild** solvent such as **mineral spirits**.
4. The silicone pad and metal must be thoroughly dry (wait at least 45min after using the solvent) and clean, before starting the bonding operation.
5. Apply adhesive sealant to the metal platen. Spread a thin even coat and apply pad immediately. Apply pressure and position pad making sure that there is no air entrapment.

NOTE: *A serrated blade such as used for laying down rubber floor tiles would be helpful for spreading the silicone paste evenly on the surface.*

6. Allow to cure for 24 hours under low pressure at normal room temperature.

FOR USE BY QUALIFIED PERSONNEL ONLY

Safety and Danger Zone Diagram

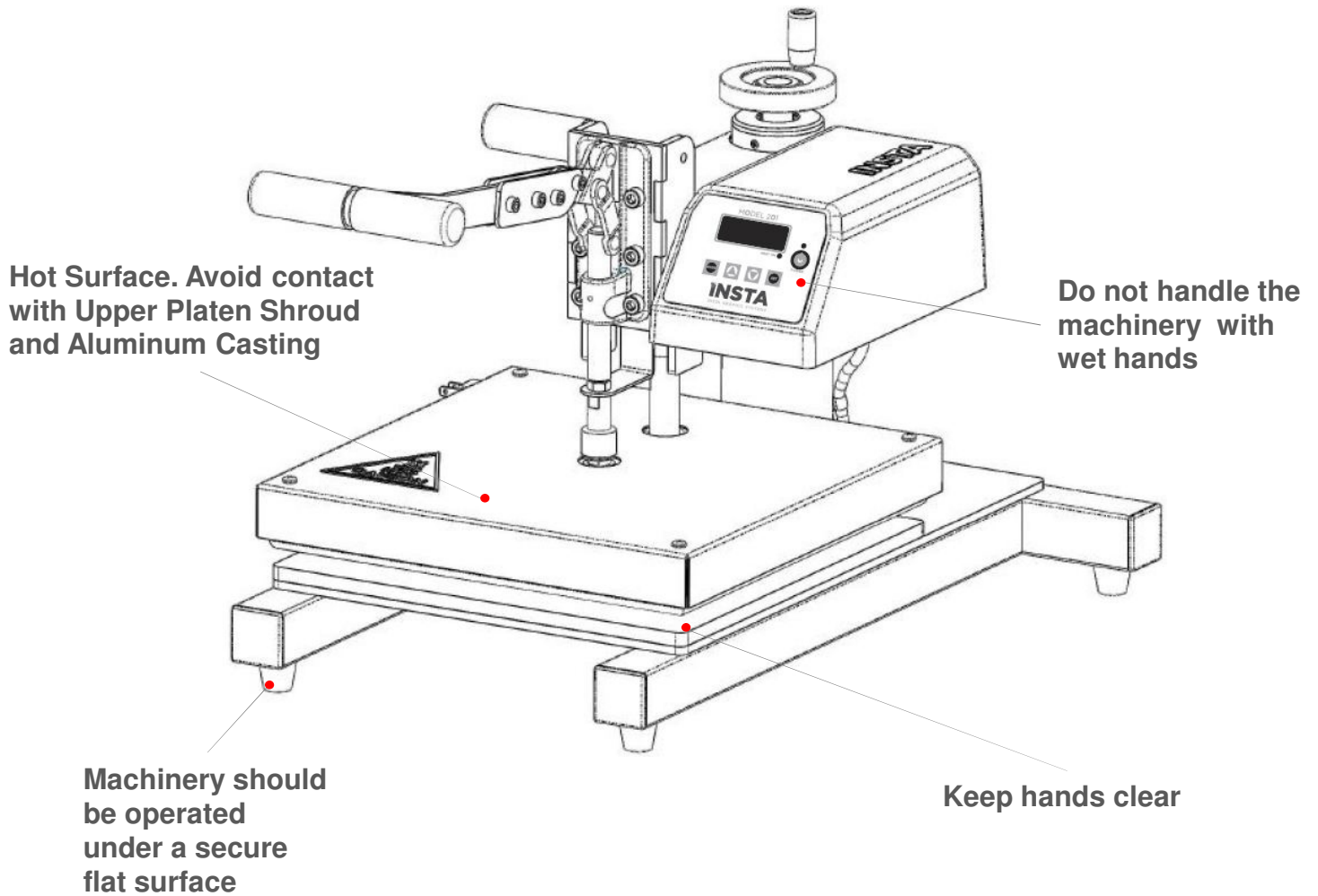

MS201 WIRING DIAGRAM

Rev. A.3 08.10.18

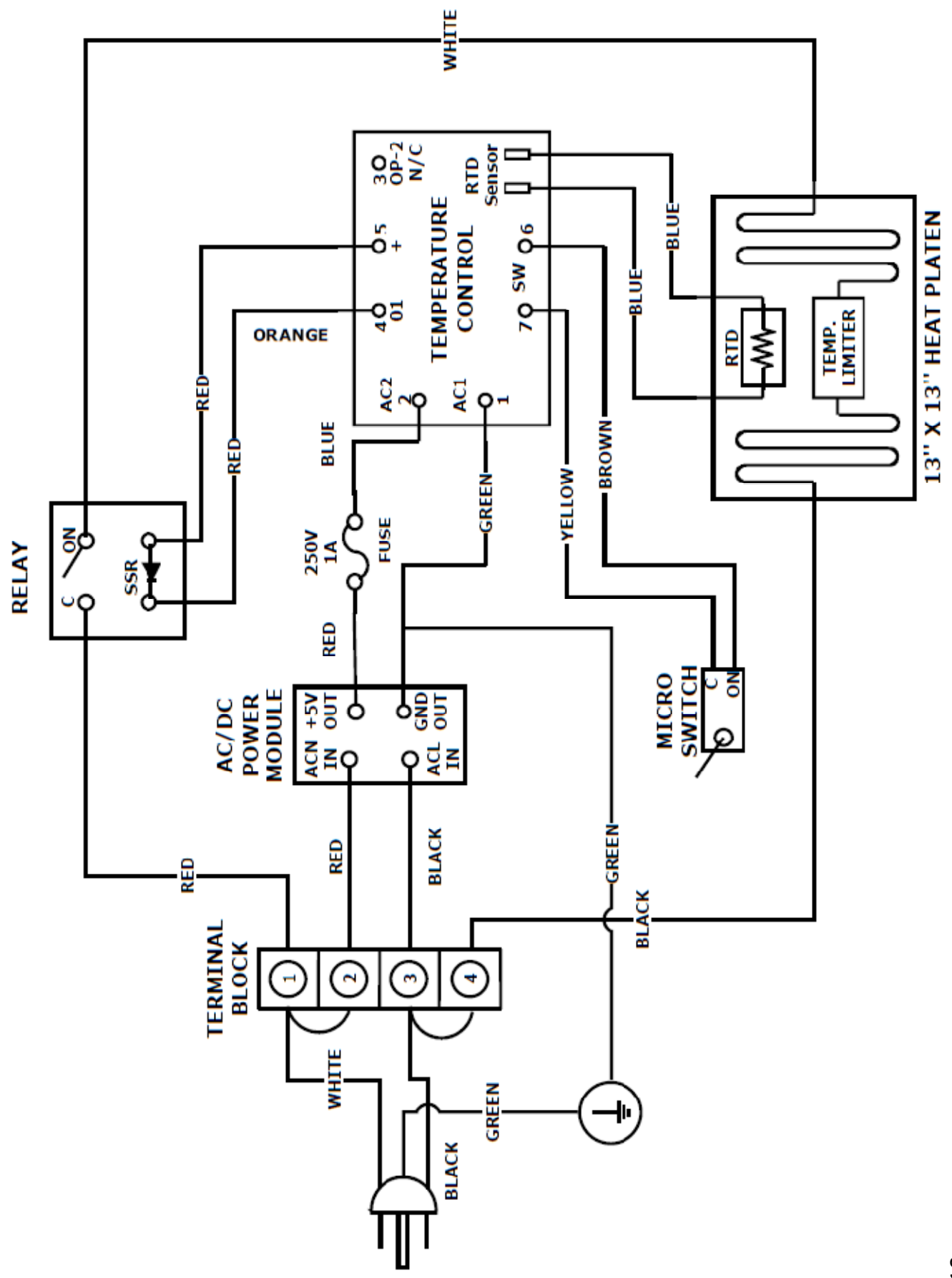

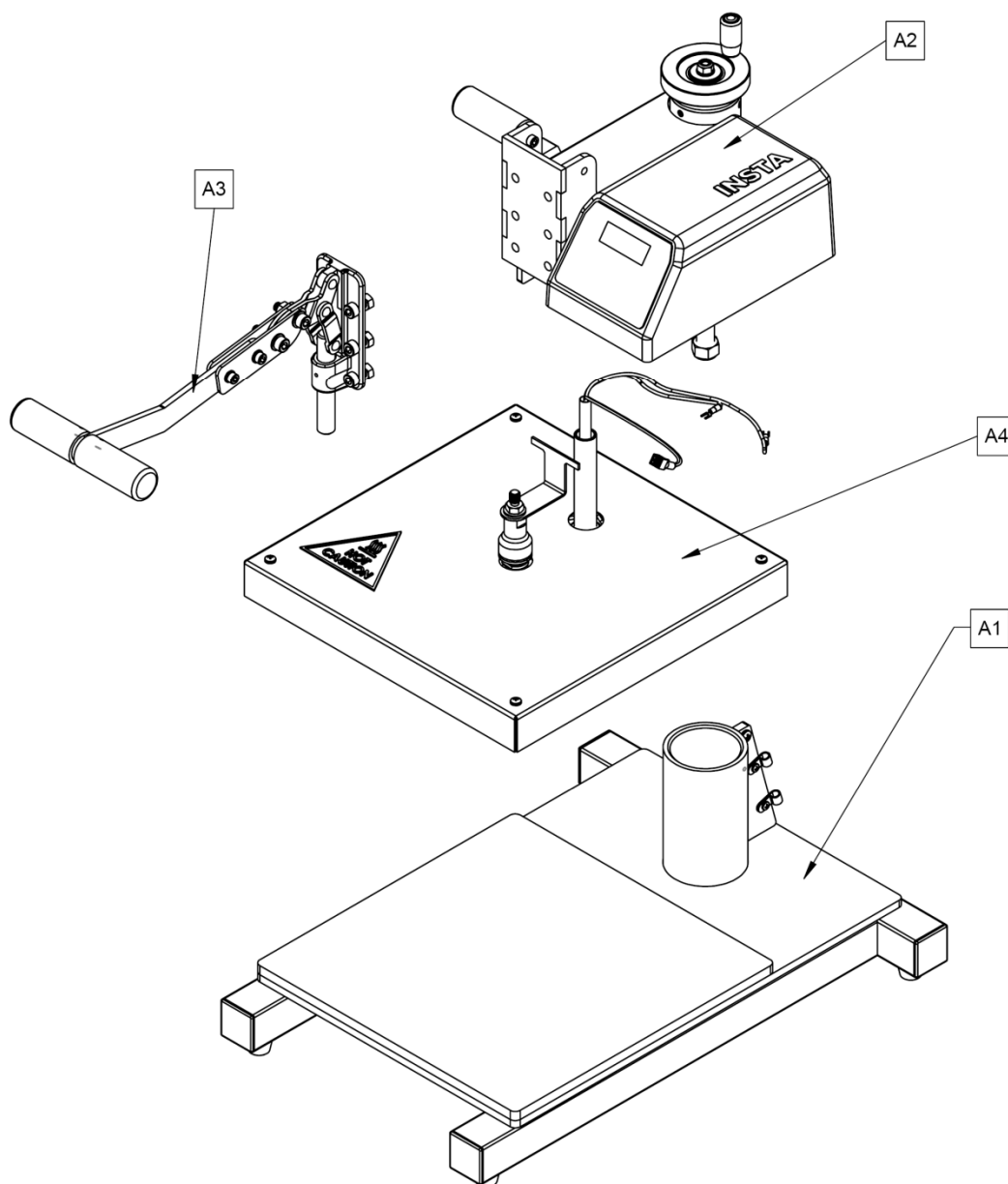
MODEL 201

ITEM NO.	ASSEMBLY NO.	DESCRIPTION	PAGE NO.
A1	MB201-002	BASE FRAME ASSEMBLY	14
A2	MB201-007	TOP FRAME ASSEMBLY	12-13
A3	MB201-003	HANDLE ASSEMBLY	15
A4	MB201-101-120/230	13 X 13 UPPER PLATEN ASSEMBLY	16

TOP FRAME ASSEMBLY

A2

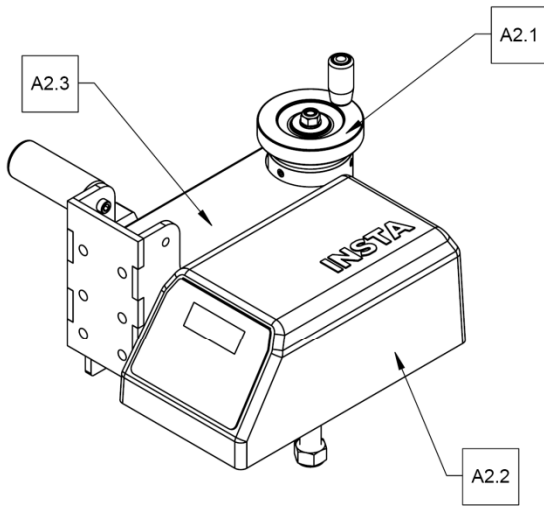

A2.1

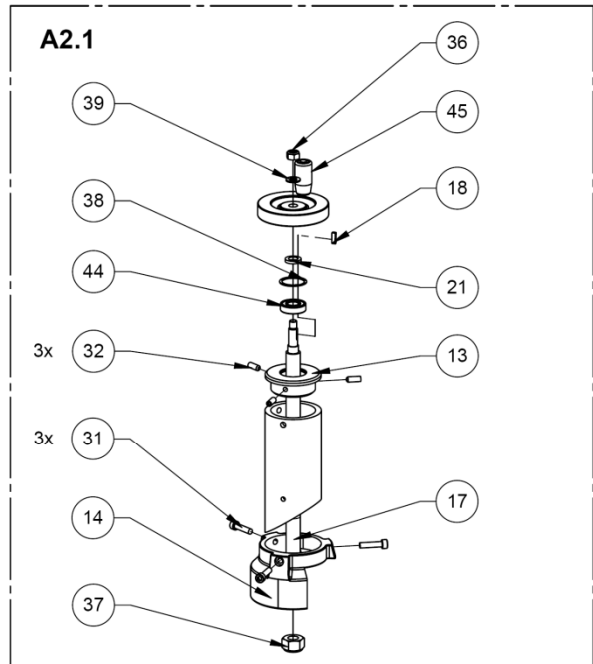

A2.2

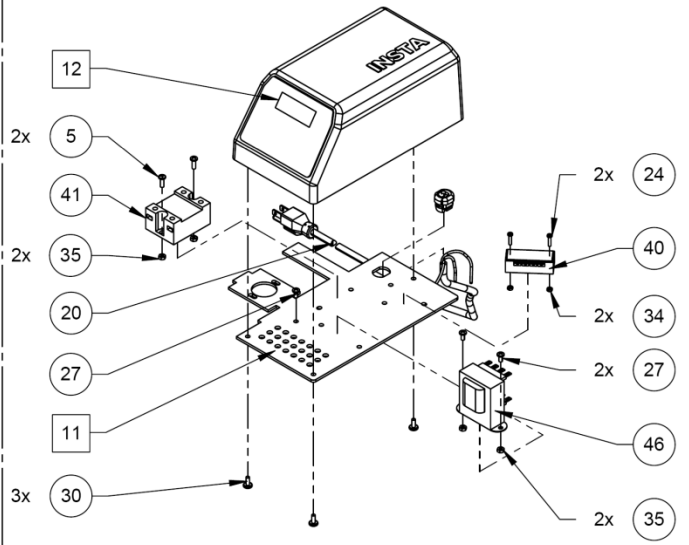

A2.3

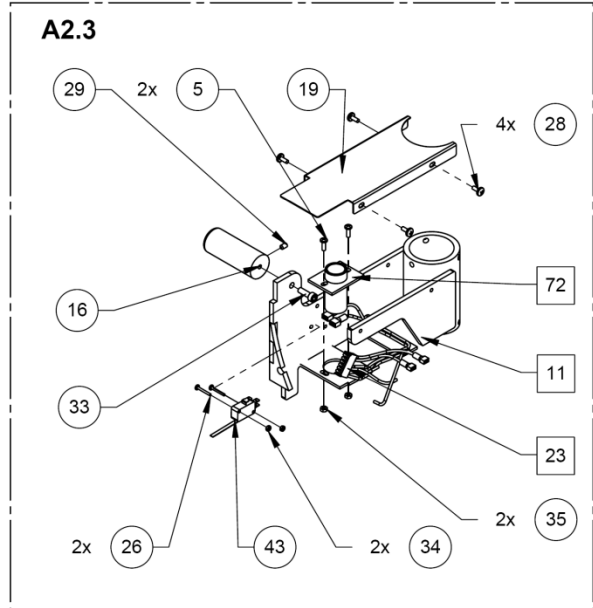

12

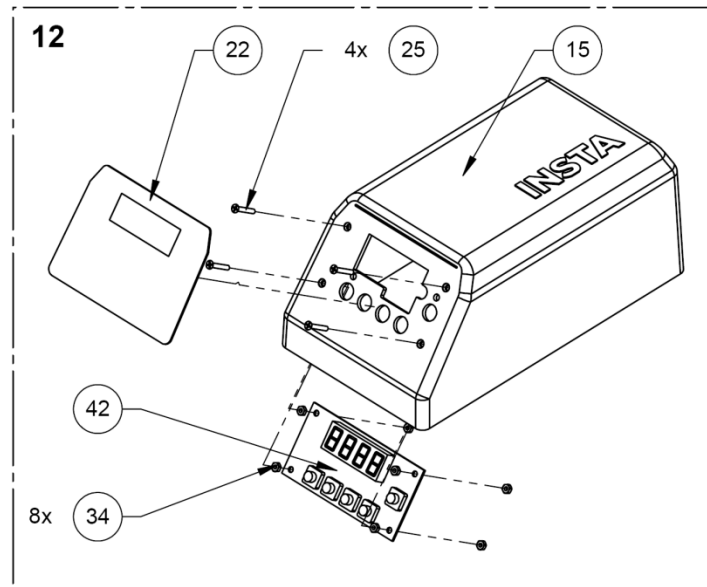

TOP FRAME ASSEMBLY

ITEM NO.	PART/ASSY. NO.	DESCRIPTION	QTY.
5	MH001-M04-001	SCREW, PAN HEAD, M4 x 0.7 x 12	4
72	MB201-005	POST GUIDE FORM	1
11	MB201-006	TOP FRAME ASSY, FORM	1
12	MB201-009	201 CONTROLLER HOUSING ASSY	1
13	MP201-031	POST CAP	1
14	MT201-032	ALIGNMENT RING, FORM	1
15	MP201-037	PLASTIC HOUSING	1
16	MP201-040	HANDLE	1
17	MP201-043-2	SCREW SHAFT	1
18	MP201-043-2B	HAND WHEEL, KEY	1
19	MP201-035	TOP FRAME COVER	1
20	MB201-047-S	CABLE ASSY, POWER (120 V)	1
20A	MB201-047-T	CABLE ASSY, POWER (230 V, EUROPE)	1
20B	MB201-047-D	CABLE ASSY, POWER (230 V, US)	1
20C	MB201-047-G	CABLE ASSY, POWER (230 V, UK)	1
21	MP201-048	BEARING WASHER	1
22	MP201-056-1A	CONTROLLER OVERLAY	1
23	MB201-079	WIRE HARNESS ASSY	1
24	MH001-M03-001	SCREW, PAN HEAD, M3 x 0.5 x 13	2
25	MH001-M03-002	SCREW, FLAT HEAD, M3 x 0.5 x 20	4
26	MH001-M03-003	SCREW, PAN HEAD, M3 x 0.5 x 20	2
27	MH001-M04-002	SCREW, PAN HEAD, M4 x 0.7 x 8	3
28	MH001-M05-001	SCREW, PAN HEAD, M5 x 0.8 x 10	4
29	MH001-M05-006	SCREW, SET, M5 x 0.8 x 8	1
30	MH001-M05-008	SCREW, SOCKET HEAD, HEX, M5 x 0.8 x 10	3
31	MH001-M06-006	SCREW, SOCKET HEAD, M6 x 1 x 25	3
32	MH001-M06-007	SCREW, SET, M6, FLAT POINT, 16 mm	3
33	MH001-M06-008	SCREW, SOCKET HEAD, M6 x 1 x 18	1
34	MH002-M03-001	NUT, HEX, M3 x 0.5	12
35	MH002-M04-001	NUT, HEX, M4 x 0.7	6
36	MH002-M08-003	LOCKNUT, NYLON-INSERT HEX, M8	1
37	MH002-M14-002	LOCKNUT, NYLON-INSERT HEX, M14	1
38	MH003-042	RETAINING RING	1
39	MH003-M08-002	WASHER, FLAT, M8 x 1.4 – 1.8	1
40	MH004-001	TERMINAL BLOCK, 4 CONTACT	1
41	MH005-001	SS RELAY	1
42	MH201-006-001	CONTROLLER, DIGITAL	1
43	MH007-003	MICROSWITCH	1
44	MH007-004	BEARING	1
45	MH007-005	HANDLE, WHEEL	1
46	MH201-008-001	TRANSFORMER, AC/DC (5V)	1

BASE FRAME ASSEMBLY

A1

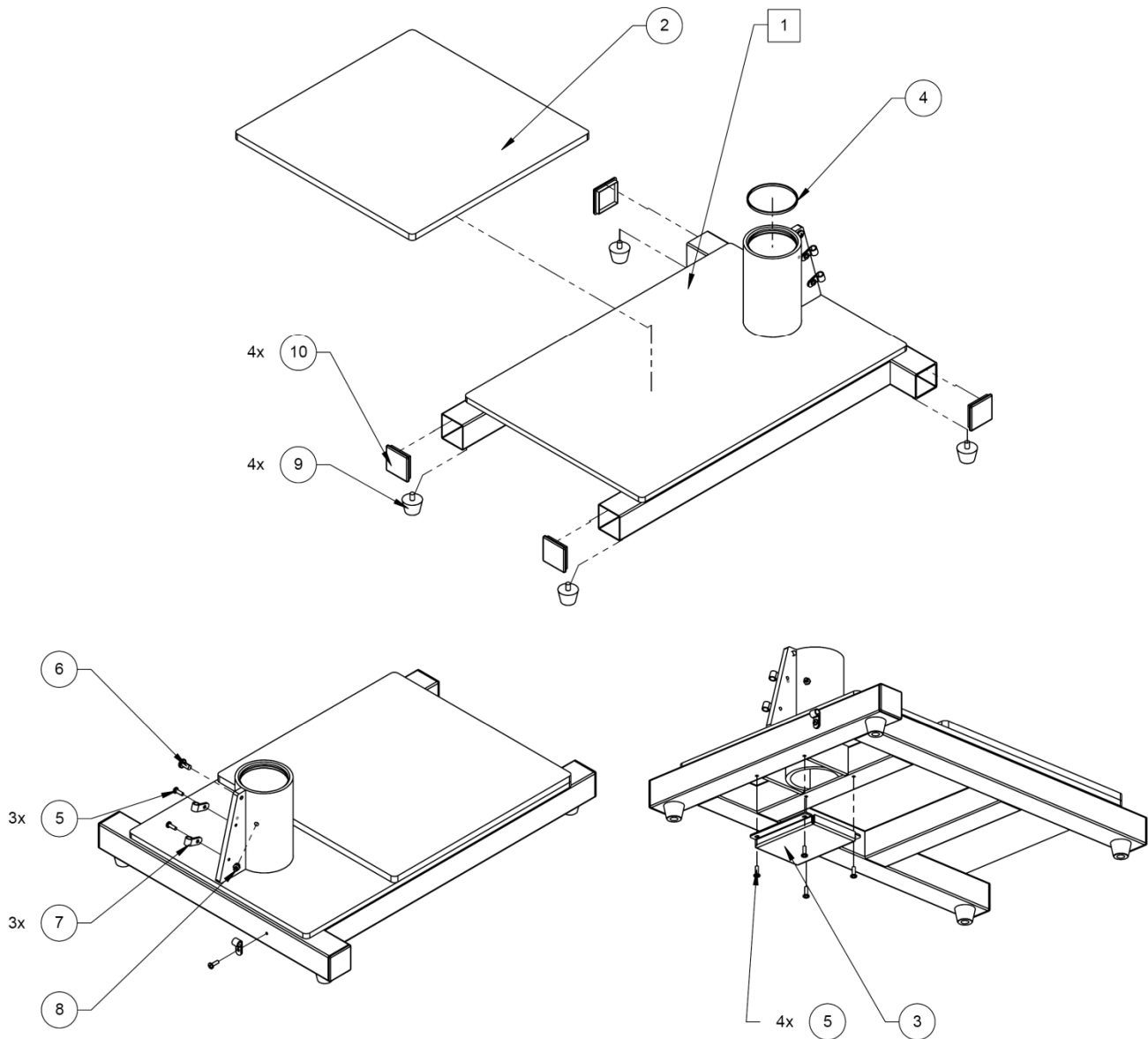

ITEM NO.	PART/ASSY. NO.	DESCRIPTION	QTY.
1	MB201-001	BASE FRAME, FORM	1
2	MP201-007	SILICONE PAD 13 X 13	1
3	MP201-010	GREASE COVER	1
4	MP201-011	GREASE WIPER	1
5	MH001-M04-001	SCREW, PAN HEAD, M4 x 0.7 x 12	7
6	MH001-M06-003	SCREW, PAN HEAD, M6 x 1.0 x 12	1
7	MH007-001	PLASTIC LOOP CLAMP	3
8	MH007-002	GREASE FITTING	1
9	MH007-010	RUBBER FOOTING	4
10	MH007-013	CAP, TUBE END	4

HANDLE ASSEMBLY

A3

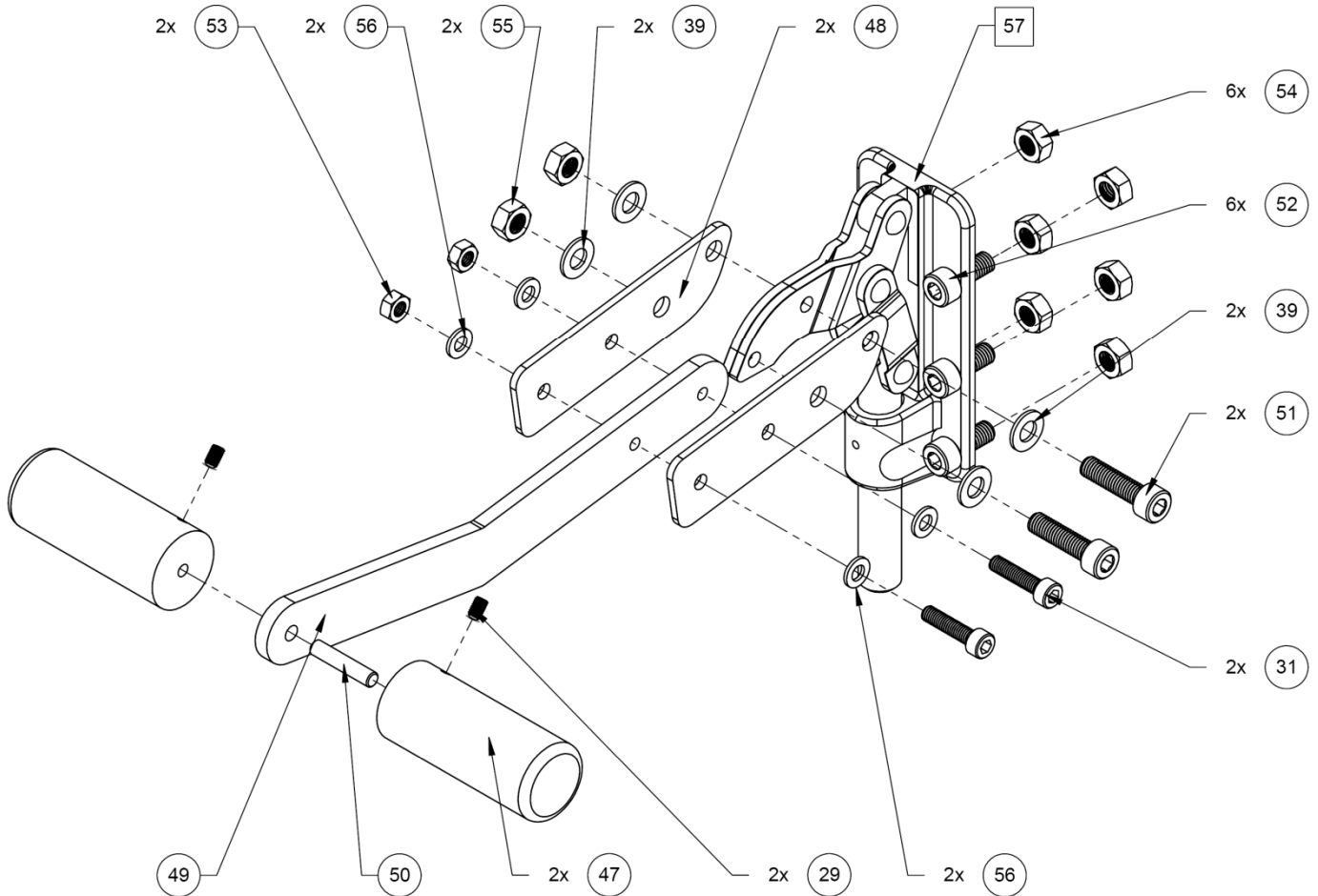

ITEM NO.	PART/ASSY. NO.	DESCRIPTION	QTY.
29	MH001-M05-006	SCREW, SET, M5 x 0.8 x 8	2
31	MH001-M06-006	SCREW, SOCKET HEAD, M6 x 1 x 25	2
39	MH003-M03-002	WASHER, FLAT, M8 x 1.4 – 1.8	4
47	MP201-040	HANDLE	2
48	MP201-111	PLATE, TOGGLE ARM ADAPTOR	2
49	MP201-112	ARM, TOGGLE	1
50	MH001-M06-004	SCREW, THREADED STUD, M6 x 35	1
51	MH001-M08-007	SCREW, SOCKET HEAD, M8 x 1.25 x 30	2
52	MH001-M08-009	SCREW, SOCKET HEAD, M8 x 1.25 x 20	6
53	MH002-M06-002	NUT, ACORN, HEX, M6 x 1	2
54	MH002-M08-001	NUT, HEX, M8	6
55	MH002-M08-004	NUT, ACORN, HEX, M8 x 1.25 x 7.8	2
56	MH003-M06-001	WASHER, M6	4
57	MH013-001	TOGGLE	1

13 X 13 UPPER PLATEN ASSEMBLY

A4

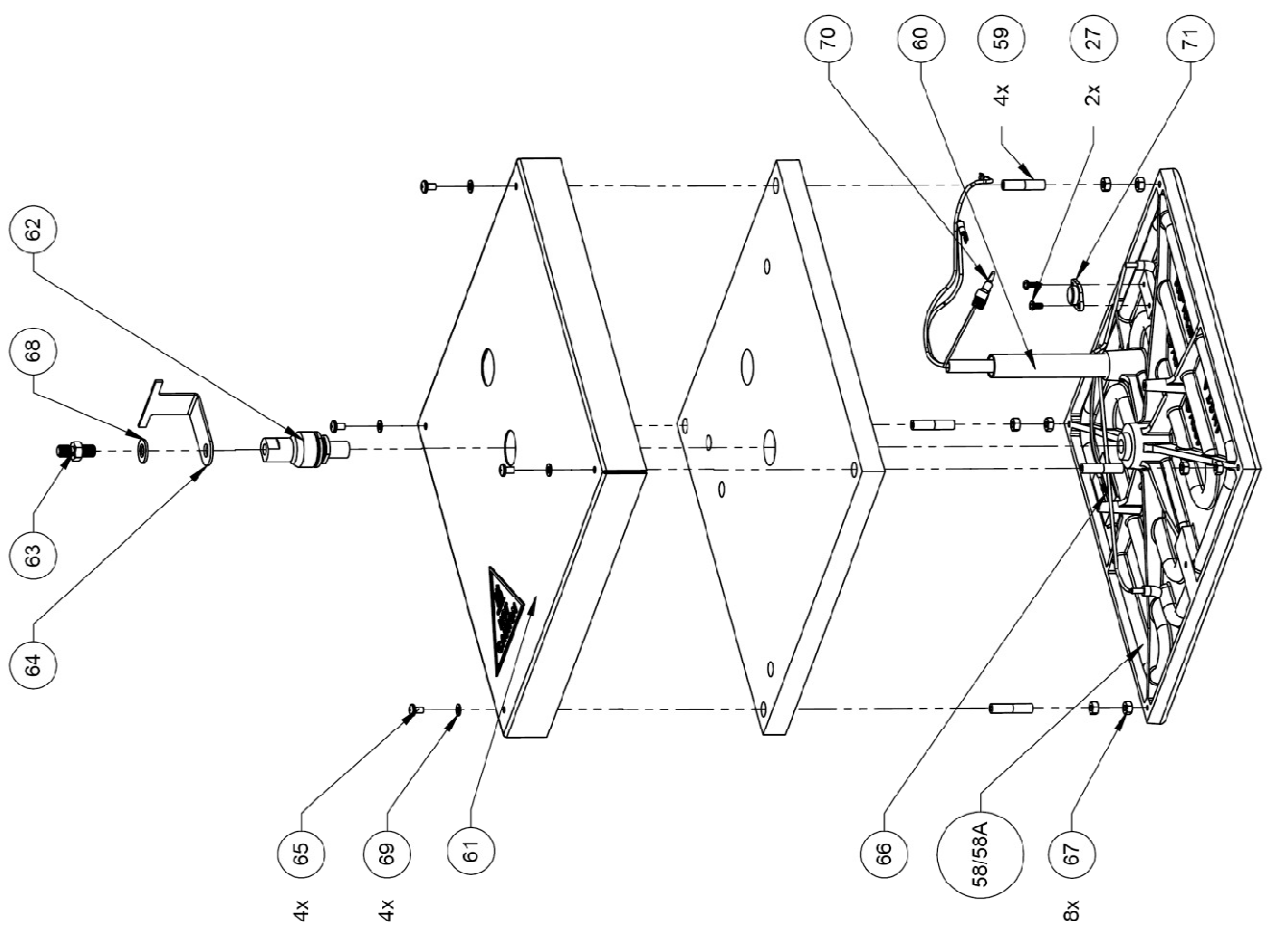

ITEM NO.	PART/ASSY. NO.	DESCRIPTION	QTY.
27	MH001-M04-002	SCREW, PAN HEAD, M4 x 0.7 x 8	2
58	MT201-001-120	PLATEN, UPPER, 13 x 13 (S)	1
58A	MT201-001-230	PLATEN, UPPER, 13 x 13 (T, D, G)	1
59	MP201-085	STANDOFF, PLASTIC	4
60	MP201-086	POST, GUIDE	1
61	MP201-087	HEAT SHROUD	1
62	MP201-088	BALL JOINT	1
63	MP201-089	ADAPTER, THREADED	1
64	MP201-090	PLATE, TRIGGER	1
65	MH001-M05-002	SCREW, PAN HEAD, M5 x 0.8 x 8	4
66	MH001-M08-001	SCREW, SET, M8 x 1.25 x 8	1
67	MH002-M06-001	NUT, HEX, M6 x 1	8
68	MH003-M10-001	WASHER, FLAT, M10	1
69	MH007-017	PROTECTIVE SCREW CUP	4
70	MH009-001	RTD SENSOR	1
71	MH009-002	TEMPERATURE LIMITER	1

FOR USE BY QUALIFIED PERSONNEL ONLY

Notes:

FOR USE BY QUALIFIED PERSONNEL ONLY

Notes:

FOR USE BY QUALIFIED PERSONNEL ONLY

Notes:



13925 E. 166th St. • Cerritos, CA USA 90703 • (800) 421-6971 • Fax (562) 404-3010

Parts Orders • (800) 426-3609 • (562) 404-3000 Ext. 215
Technical Support • (800) 426-3609 • (562) 404-3000 Ext. 208
In House Repair • (800) 426-3609